

PART – A:

- A granite block of $2\text{m} \times 5\text{m} \times 3\text{m}$ size is cut into 5 cm thick slabs of $2\text{m} \times 5\text{m}$ size. These slabs are laid over a 2m wide pavement. What is the length of the pavement that can be covered with these slabs?
 - 100 m
 - 200 m
 - 300 m
 - 500 m
- Which is the least among the following?

$$0.33^{0.33}, \quad 0.44^{0.44}, \quad \pi^{-1/x}, \quad e^{-1/e}$$
 - $0.33^{0.33}$
 - $0.44^{0.44}$
 - $\pi^{-1/x}$
 - $e^{-1/e}$
- What is the next number in this “see and tell” sequence?

$$1 \quad 11 \quad 21 \quad 1211 \quad 111221$$
 - 312211
 - 1112221
 - 1112222
 - 1112131
- A vertical pole of length a stands at the centre of a horizontal regular hexagonal ground of side a . A rope that is fixed taut in between a vertex on the ground and the tip of the pole has a length
 - a
 - $\sqrt{2}a$
 - $\sqrt{3}a$
 - $\sqrt{6}a$
- A peacock perched on the top of a 12 m high tree spots a snake moving towards its hole at the base of the tree from a distance equal to thrice the height of the tree. The peacock flies towards the snake in a straight line and they both move at the same speed. At what distance from the base of the tree will the peacock catch the snake?
 - 16 m
 - 18 m
 - 14 m
 - 12 m
- The cities of a country are connected by intercity roads. If a city is directly connected to an odd number of other cities, it is called an odd city. If city is directly connected to an even number of other cities, it is called an even city. Then which of the following is impossible?
 - There are an even number of odd cities
 - There are an odd number of odd cities
 - There are an even number of even cities
 - There are an odd number of even cities

7. In the figure $\angle ABC = \pi/2$

$$AD = DE = EB$$

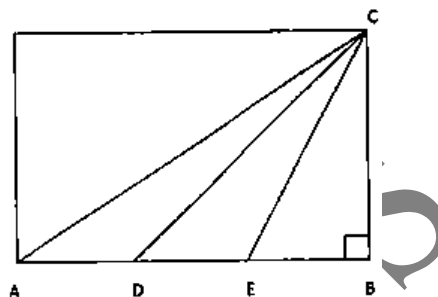

What is the ratio of the area of triangle ADC to that of triangle CDB?

- 1 : 1
 - 1 : 2
 - 1 : 3
 - 1 : 4
8. A rectangular sheet ABCD is folded in such a way that vertex A meets vertex C, there by forming a line PQ. Assuming $AB = 3$ and $BC = 4$, find PQ. Note that $AP = PC$ and $AQ = QC$.

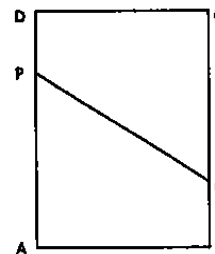

- $13/4$
 - $15/4$
 - $17/4$
 - $19/4$
9. A string of diameter 1mm is kept on a table in the shape of a close flat spiral i.e. a spiral with no gap between the turns. The area of the table occupied by the spiral is 1m^2 . Then the length of the string is
- 10 m
 - 10^2 m
 - 10^3 m
 - 10^6 m
10. 25% of 25% of a quantity is x% of the quantity where x is
- 6.25 %
 - 12.5 %
 - 25 %
 - 50 %
11. In sequence $[a_n]$ every term is equal to the sum of all its previous terms.

If $a_0 = 3$, then $\lim_{n \rightarrow \infty} \frac{a_{n+1}}{a_n}$ is

- (1) 3 (2) 2
(3) 1 (4) e

12. In the figure below, angle $ABC = \pi/2$, I, II, III are the areas of semicircles on the sides opposite angles B, A, and C, respectively. Which of the following is always true?

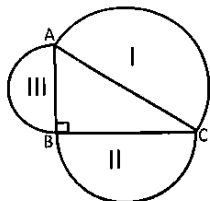

- (1) $II^2 + III^2 = I^2$ (2) $II + III = I$
(3) $II^2 + III^2 > I^2$ (4) $II + III < I$

13. What is the minimum number of days between one Friday the 13th and the next Friday the 13th? (Assume that the year is a leap year).

- (1) 28 (2) 56
(3) 91 (4) 84

14. Suppose a person A is at the North-East corner of a square (see the figure below). From that point he moves along the diagonal and after covering $1/3^{\text{rd}}$ portion of the diagonal, he goes to his left and after sometime he stops, rotates 90° clockwise and moves straight. After a few minutes he stops, rotates 180° anticlockwise. Towards which direction he is facing now?

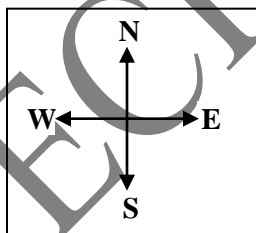

- (1) North-East (2) North-West
(3) South-East (4) South-West

15. Cucumber contains 99% water. Ramesh buys 100 kg of cucumbers. After 30 days of storing, the cucumbers lose some water. They now contain 98% water. What is the total weight of cucumbers now?

- (1) 99 kg (2) 50 kg
(3) 75 kg (4) 2 kg

16. In a museum there were old coins with their respective years engraved on them, as follows.

- (A) 1837 AD (B) 1907 AD
(C) 1947 AD (D) 200 BC

Identify the fake coin(s)

- (1) coin A (2) coin D
(3) coin A and B (4) coin C

17. A student observes the movement of four snails and plots the graphs of distance moved as a function of time as given in figures (A), (B) (C) and (D).

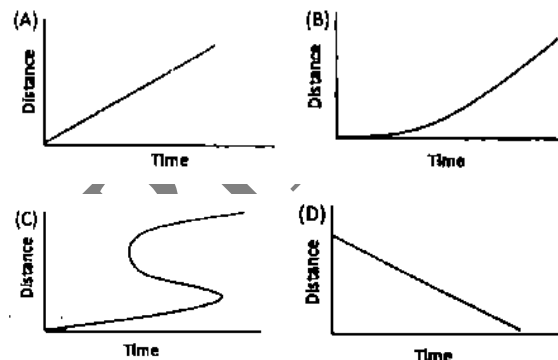

Which of the following is not correct?

- (1) Graph (A) (2) Graph (B)
(3) Graph (C) (4) Graph (D)

18. Find the missing letter:

- (1) H
(2) L
(3) Z
(4) Y

A	EGK	C
?		P
U		R
Q		V
B	OJF	D

19. Consider the following equation

$$x^2 + 4y^2 + 9z^2 = 14x + 28y + 42z + 147$$

where x , y and z are real numbers. Then the value of $x + 2y + 3z$ is

- (1) 7 (2) 14
(3) 21 (4) not unique

20. The map given below shows a meandering river following a semi-circular path, along which two villages are located at A and B. The distance between A and B along the east-west direction in the map is 7cm. What is the length of the river between A and B in the ground?

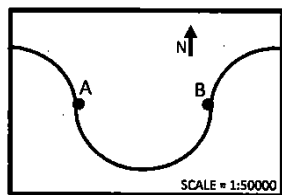

- (1) 1.1 km (2) 3.5 km
 (3) 5.5 km (4) 11.0 km

PART – B:-

21. Out of the following hydrogen bonding schemes shown by ..., which one corresponds to the weakest hydrogen bond in a given solvent condition?

- (1) O – H O < (2) N – H ... O <
 (3) O – H N < (4) N – H N <

22. Which peptide bond(s) marked as a, b, c, d and e will be broken when the following oligopeptide is treated with trypsin at pH 7.0?

Lys

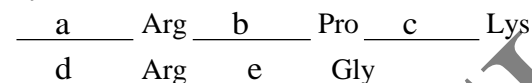

- (1) a, b, d, e (2) b, d, e
 (3) d, e (4) d

23. In cellular respiration, which of the following processes occur only inside mitochondria and not in the cytoplasm?

- (1) Glycolysis and the pentose – phosphate pathway.
 (2) Glycolysis and the citric acid cycle.
 (3) The citric acid cycle and oxidative phosphorylation.
 (4) Glycolysis and oxidative phosphorylation.

24. An enzyme catalysed reaction was measured in the presence and absence of an inhibitor. For an uncompetitive inhibition,

- (1) only K_m is increased
 (2) both K_m and V_{max} are decreased
 (3) only V_{max} is decreased
 (4) both K_m and V_{max} are not affected.

25. KCl (100 mM) was entrapped inside large unilamellar vesicles. A diffusion potential across

the bilayer can be generated by diluting with buffer containing

- (1) 100 mM KCl and a protonophore.
 (2) 100 mM NaCl and a protonophore.
 (3) 100 mM KCl and a K^+ -specific ionophore.
 (4) 100 mM NaCl and a K^+ -specific ionophore.

26. Acetylcholine receptor is an archetype for:

- (1) Ligand-gated ion channel
 (2) ATPase dependent voltage-gated ion channel
 (3) ATPase dependent Ca^{2+} -gated ion channel
 (4) ATPase independent voltage gated ion channel

27. With reference to lac operon, what will be the phenotype of an E coli strain having a genotype $i^- o^+ z^+ y^- / F^+ i^+ o^e z^- y^+$?

- (1) Constitutive for both β -galactosidase and lac permease.
 (2) Inducible for both β -galactosidase and lac permease.
 (3) Inducible for β -galactosidase and constitutive for lac permease.
 (4) Constitutive for β -galactosidase and inducible for lac permease.

28. An organism that has peroxidase and superoxide dismutase but lacks catalase is most likely an

- (1) aerotolerant anaerobe
 (2) aerotolerant aerobe
 (3) obligate anaerobe
 (4) facultative anaerobe

29. During DNA replication, events at the replication fork require different types of enzymes having specialized functions except
- (1) DNA polymerase III
 - (2) DNA gyrase
 - (3) DNA ligase
 - (4) DNA glycosylase
30. Which of the following names is appropriate for the sequence 5'-G/ANNAUG-3' in a mammalian mRNA?
- (1) Shine-Dalgarno sequence
 - (2) Kozak sequence
 - (3) Internal ribosome entry sites
 - (4) Translation termination site
31. The specificity of tRNA recognition by an aminoacyl tRNA synthetase that is intrinsic to the tRNA molecule lies on
- (1) acceptor stem
 - (2) acceptor stem and anticodon loop
 - (3) anticodon loop
 - (4) D-arm.
32. Viral gene expression after T3 bacteriophage infection is controlled by:
- (1) repressor molecule
 - (2) slow injection of nucleic acid
 - (3) modification of RNA polymerase
 - (4) DNA polymerase.
33. Which of the following factors is NOT true for the low levels of immune response in Plasmodium infection?
- (1) Different types of antigens are expressed at various stages of *Plasmodium* life cycle.
 - (2) Most of the phases in the life cycle of *Plasmodium* are intracellular.
 - (3) Sporozoites are rapidly cleared from blood circulation.
 - (4) *Plasmodium* infection primarily destroys macrophages and dendritic cells.
34. Presence of the nuclear localization signal (NLS) in a steroid receptor indicates that the receptor resides
- (1) on the nuclear membrane
 - (2) within the nucleus
 - (3) on the cell membrane
 - (4) in the cytosol
35. Which of the following is an intracellular anchor protein?
- (1) Vitronectin
 - (2) Vinculin
 - (3) Integrin
 - (4) Elastin
36. Out of the following matches of oncogenes with the proteins that each specifies, which one is incorrect?
- (1) *erbA* – thyroid hormone receptor.
 - (2) *erbB* – epidermal growth factor receptor.
 - (3) *ras* – guanine-nucleotide binding protein with GTPase activity.
 - (4) *fos* – platelet-derived growth factor.
37. Capacitation of sperms in humans
- (1) occurs during copulation
 - (2) occurs after the acrosome reaction.
 - (3) takes place in the ampulla of the oviduct.
 - (4) takes place in the epididymis of testis.
38. With respect to development of any organism, “autonomous specification” would result in which type of development?
- (1) Regulative
 - (2) Mosaic
 - (3) Syncytial
 - (4) Definitive
39. The group of cells which generates the vascular tissues including the pericycle in roots of higher plants are called
- (1) procambium
 - (2) protoderm
 - (3) ground meristem
 - (4) apical meristem.
40. If an embryo undergoes 13 cleavage divisions during embryogenesis, then the size of the embryo compared to zygote
- (1) increases 13 times
 - (2) increases in an exponential fashion
 - (3) increases only 6 – 7
 - (4) remains almost the same.
41. The chlorosis (yellowing) symptom of iron deficiency is influenced by
- (1) Sodium and Potassium
 - (2) Sodium and Phosphorus
 - (3) Calcium and Nitrogen
 - (4) Potassium and Phosphorus.

42. A plant hormone that promotes the acquisition of desiccation tolerance in developing seed is

- (1) ABA (2) Ethylene
(3) IAA (4) GA3.

43. Change in Ca^{2+} concentration can initiate various responses in plants. Which one of the following responses is NOT known to be initiated by change in Ca^{2+} concentration?

- (1) Closure of stomata.
(2) Reorientation of growth in pollen tubes.
(3) Thickening of cell walls in young tobacco seedlings in response to wind.
(4) Lateral root formation.

44. Water can move through the soil-plant-atmosphere continuum, only if water potential (ψ_w) along that path

- (1) decreases
(2) increases
(3) remains unchanged
(4) fluctuates rapidly in either direction.

45. Which one of the following is responsible for the ejection of milk from mammary glands in mammals?

- (1) Oxytocin (2) Prolactin
(3) Serotonin (4) Melatonin

46. A nerve fibre cannot be stimulated during the absolute refractory period of a previous stimulus because

- (1) sodium permeability remains high.
(2) sodium-potassium pump does not operate.
(3) voltage-gated calcium channels remain closed.
(4) potassium conductance remains low.

47. The T-wave of ECG indicates

- (1) atrial depolarization
(2) ventricular depolarization
(3) ventricular repolarization
(4) atrial repolarization

48. Blood group type A antigen is a complex oligosaccharide which differs from H antigen present in type O individual by the presence of terminal

- (1) glucose (2) galactose
(3) N-acetyl galactosamine (4) fucose

49. A cross was made between pure wild type males and brown eyed, curled winged females of *D. melanogaster*. The F_1 females were test crossed. The F_2 progeny obtained was as follows:

Wild type	200
Brown eyes, curled wings	150
Brown eyes, normal wings	30
Normal eyes, curled wings	20
Total	400

The genetic distance (cM) between brown eye and curled wing loci is:

- (1) 12.5 (2) 50
(3) 150 (4) 25

50. The effect of nonsense mutation could be nullified by reversion as well as suppression. Which of the following processes will help to distinguish between the two kinds of revertants?

- (1) Complementation (2) Transgenesis
(3) Test for allelism (4) Recombination

51. 2-Aminopurine induces mutation by

- (1) base pair change (2) frameshift
(3) duplication (4) insertion

52. In a transformation experiment, donor DNA from an *E. coli* strain with the genotype $Z^+ Y^+$ was used to transform a strain of genotype $Z^- Y^-$. The frequencies of transformed classes were:

$Z^+ Y^+$	200
$Z^+ Y^-$	400
$Z^- Y^+$	400
Total	1000

What is the frequency (%) with which Y locus is cotransformed with the Z locus?

- (1) 1 (2) 20
(3) 33.3 (4) 40

53. The 'Tribe' refers to a taxonomic group recognized between the ranks

- (1) Genus and species
(2) family and genus
(3) Order and family

(4) class and order

54. A plant species has been described for the first time by author 'x'. Later, the species has been transferred to some other genus by author 'y'. the author citation or the new combination will be

- (1) x et y (2) x ex y
(3) (x) y (4) (y) x

55. The group which is no longer considered under fungi is

- (1) Ascomycetes (2) Basidiomycetes
(3) Chytridiomycetes (4) Oomycetes

56. Character similarity that can be misinterpreted as common descent is called

- (1) symplesiomorphy (2) synapomorphy
(3) Homology (4) homoplasy

57. The following table shows survival and fertility data for a seasonally breeding species.

Season	Proportion Surviving	Fertility
0	1.0	0
1	0.5	20
2	0.0	-

Based on above data, net reproductive rate (R_0) of the species will be

- (1) 1 (2) 5
(3) 10 (4) 20

58. Which of the following is NOT characteristic of late successional forest plant species?

- (1) Large seed size, high root to shoot ratio
(2) Long seed dispersal distance, long seed viability.
(3) Slow growth rate, long maximum life span.
(4) Low light saturation intensity, high efficiency at low light.

59. Which of the following organisms do not possess the ability to fix nitrogen?

- (1) Organisms specialized for high altitude
(2) Marine plankton
(3) Eukaryotic organisms
(4) Acidophilic organisms

60. Which of the following green house gases has got highest atmosphere lie time?

- (1) CO₂ (2) N₂O
(3) CH₄ (4) CFCs

61. Which of the following evolutionary processes played an important role in the evolution of complex immune system?

- (1) Reproductive isolation
(2) Adaptive radiation
(3) Neutral evolution
(4) Co – evolution

62. In some species of new world monkeys, only one female reproduction and assist the reproductive female.

- (1) Sexual selection
(2) Group selection
(3) Kin selection
(4) Reciprocal selection

63. In bird species where both parents contribute equally to parental care, generally

- (1) Males are larger than females
(2) Females are more colorful than males.
(3) Females are larger than males.
(4) Both sexes are morphologically similar.

64. The ideas that an altruistic gene will be favored if $r > C/B$, where r is the coefficient of relatedness, B is the benefit to the recipient of the altruism, and C is the cost incurred to the donor, is known as

- (1) Red queen hypothesis
(2) Handicap principle.
(3) Hamilton's rule
(4) Competitive exclusion principle.

65. Use of doubled haploid in plant breeding helps to

- (1) Reduce generation time while intercrossing recessive traits.
(2) Reduce generation time while intercrossing dominant traits.
(3) Develop somatic hybrids.
(4) Interbreed transgenic traits.

66. For sustained expression of a transgene in the successive generation of a cell line in culture, the ideal gene transfer can be obtained using
- (1) Lentiviral vector.
 - (2) Adenoviral vector.
 - (3) Plasmid DNA containing the transgene.
 - (4) Only transgenic DNA.
67. *Desulphovibrio desulfuricans* (A) and *Pseudomonas* species (B) are involved in mercury bioremediation. Which of the statements below is correct?
- (1) A converts methyl mercury to mercuric ion, B converts mercury to methyl mercury.
 - (2) A converts mercury to methyl mercury, B converts mercury to mercuric ion
 - (3) A converts mercury to methyl mercury, B converts methyl mercury to mercuric ion.
 - (4) A converts methyl mercury to mercuric ion, B converts mercury to mercuric ion.
68. Optical density of a 400 base pair long 1 ml DNA solution was found to be 0.052. How many DNA molecules are present in the solution?

[1 base pair = 650 dalton, optical density of 1.0 D corresponds to 50 μg DNA/ml]

- (1) 6.023×10^{12}
- (2) 6.023×10^{18}
- (3) 4.633×10^{18}
- (4) 5.2×10^{13}

69. In which of the following techniques does molecules fragmentation offer clues to the covalent chemical structures of biomolecules?
- (1) MALDI-TOF MS mass spectrometry.
 - (2) MALDI-TOF MS/MS mass spectrometry.
 - (3) ESI- TOF MS mass spectrometry.
 - (4) LC-coupled ESI-TOF MS mass spectrometry.
70. The movement of a single cell was required to be continually monitored during development. This cell was marked with a reporter gene. To visualize this movement one would use
- (1) phase contrast microscopy
 - (2) bright field microscopy
 - (3) fluorescence microscopy
 - (4) atomic force microscopy

PART - C :-

71. The Gibbs free energy of binding of a ligand with a protein is determined using calorimetric measurements at 25°C. The value of ΔG° thus determined is 1.36 kcal/mole. The binding constant for the ligand-protein association is:
- (1) 1.30×10^{-12}
 - (2) 0.10
 - (3) 1.00
 - (4) 0.97
72. A is converted to E by enzymes E_A , E_B , E_C , E_D . The K_m (M) values of the enzymes are 10^{-2} , 10^{-4} , 10^{-5} and 10^{-4} , respectively. If all the substrates and products are present at a concentration of 10^{-4} M, and the enzymes have approximately the same V_{max} , the rate limiting step will be:

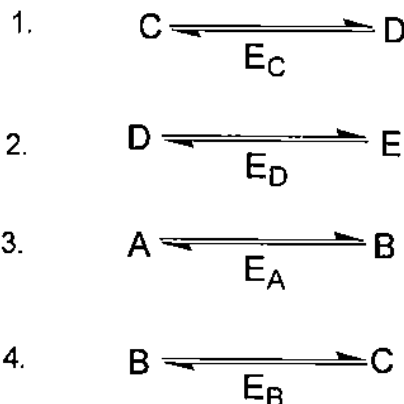

73. The molecular mass of a protein determined by gel filtration is 120 kDa. When its mass is determined by SDS-PAGE with and without β -mercaptoethanol, it is only 60 kDa. What is the most probable explanation for these observations?

- (1) Protein is a dimer in which two identical chains are cross-linked by disulphide bond(s).
- (2) Protein is a monomer of molecular mass 60 kDa but it is excluded from the gel matrix due to strong repulsion between the gel matrix and the protein.
- (3) Protein is most likely to be composed of two sub-units having identical molecular mass.
- (4) Protein is a monomer but it is nicked into half its size by SDS.

74. Mouse IgG is left either intact (left lane in A, B, C, D) or digested with papain or treated with β -mercaptoethanol (β -ME) and run on non-reducing SDS-PAGE and stained with Coomassie blue. In a separate experiment, papain-digested products are immunoblotted with an anti-idiotypic monoclonal antibody. Following four profiles are attributed to each of these treatments.

Which one of the following possibilities is correct?

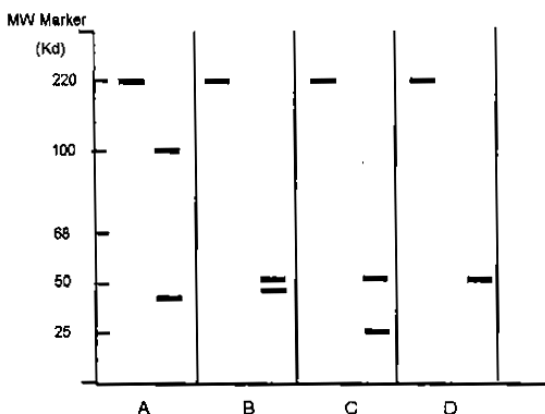

- (1) A (pepsin), B (Papain), C(β -ME), D(papain, followed by anti-idiotypic immunoblot)
- (2) A (papsin), B (pepsin), C (papain, followed by anti-idiotypic immunoblot, D(β -ME)
- (3) A (pepsin, followed by anti-idiotypic immunoblot), B(papain), C (pepsin), D (β -ME)
- (4) A (β -ME), B(papain), C(pepsin), D(papain, followed by anti-idiotypic immunoblot)

75. The citric acid cycle in respiration yields:

- (1) 1 GTP, 3 NADH, 1 FADH₂, 2 CO₂
- (2) 2 GTP, 2 FADH₂, 6NADH, 2CO₂

- (3) 4 GTP, 6 NADH, 4 FADH₂, 2 CO₂
- (4) 32 GTP, 2 NADH, 4 FADH₂, 4 CO₂

76. Phosphatidyl serine (PS) is mostly located in the inner bilayer of plasma membrane of red blood cells (RBCs). You have to prove this fact about PS by an experiment. You are provided with PS-specific lytic enzymes (PSE) and other reagents needed.

Identify the correct sequence of experiments to be carried out to settle this issue.

- (1) RBCs \rightarrow inside out vesicles \rightarrow TLC \rightarrow PSE
- (2) RBCs \rightarrow right side out vesicles \rightarrow TLC \rightarrow PSE
- (3) RBCs \rightarrow PSE \rightarrow Inside out vesicles \rightarrow TLC
- (4) RBCs \rightarrow PSE \rightarrow TLC \rightarrow Inside out vesicles

77. ATP-driven pumps hydrolyze ATP to ADP and phosphate and use the energy released to pump ions or solutes across a membrane. There are many classes of these pumps and representatives of each are found in all prokaryotic and eukaryotic cells. Which of the following statements about these pumps is NOT correct?

- (1) P-type pumps are multipass transmembrane proteins which phosphorylate themselves during pumping and involve in ion transport.
- (2) F-type pumps normally use the H⁺ gradient across the membrane to drive the synthesis of ATP.
- (3) V-type pumps normally use voltage gradient for transport of small molecules.
- (4) ABC transporters primarily pump small molecules across cell membrane.

78. Following are statements related to the organization of the four major protein complexes of thylakoid membrane.

- (A) Photosystem II is located predominantly in the stacked regions of the thylakoid membrane.
- (B) Photosystem I is found in the unstacked regions protruding into stroma.
- (C) Cytochrome B₆ f complex is confined to stroma only.
- (D) ATP synthase is located in the unstacked regions protruding into stroma.

Which one of the following combinations of above statements is correct?

- (1) A, B, and C (2) A, B, and D
 (3) B, C and D (4) C, D and A

79. A bacterial population has a plasmid with copy number 'n'. It was observed that on an average in one out of $2^{(n-1)}$ cell divisions, there was spontaneous plasmid curing. It was inferred from the observation that :

- (A) Each cell division does not have equal probability of plasmid curing.
 (B) There is no evidence for any mechanism of plasmid segregation in the two daughter cells.
 (C) Plasmid distribution to daughter cells is random.
 (D) Each plasmid has an equal chance of being in either of the two daughter cells.

Which of the combinations of above statements is true?

- (1) A and B (2) B and D
 (3) only A (4) B, C and D

80. In a given experiment the cells were labeled for 30 minutes with radioactive thymidine. The medium was then replaced with that containing unlabelled

thymidine and the cells were grown for additional time. At different time points after replacement of medium the fraction of

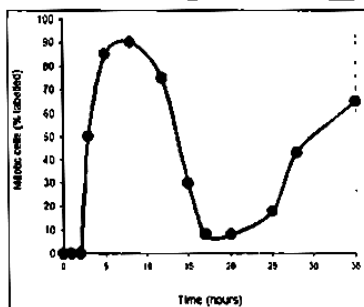

of mitotic cells were analysed. Based on the results obtained, the above figure was drawn which shows the percentage of mitotic cells that are labeled as a function of time after brief incubation with radioactive thymidine.

Considering the above experiment, the following statement were made:

- (A) Cells in the S-phase of the cell cycle during the 30 minute labeling period contain radioactive DNA.

(B) It takes about 3 hours before the first labeled mitotic cells appear.

(C) The cells enter the second round of mitosis at t_{30} hours.

(D) The total length of the cell cycle is about 27 hours with G_1 being more than 15 hours.

Which of the combinations of the above statements is correct?

- (1) A and B (2) B and C
 (3) C and D (4) A and D

81. Mutants of *lac Y* (Y^-) gene of E.coli do not synthesize the lactose permease protein. The following statements refer to the behaviour of *lac Y^-* mutants under different experimental conditions.

(A) No synthesis of β -galactosidase when Y^- cells are induced with lactose.

(B) Synthesis of β -galactosidase when cells are induced with lactose.

(C) No synthesis of β -galactosidase when cells are induced with IPTG.

(D) Synthesis of β -galactosidase when cells are induced with IPTG.

(E) The cells induced with IPTG cannot grow in the presence of TONPG (TONPG is a compound, whose uptake is mediated by lactose permease and cleaved by β -galactosidase to release a toxic compound).

(F) Cells induced with IPTG can grow in the presence of TONPG.

Which combination of the above statements is correct?

- (1) A, D and F (2) B, C and E
 (3) A, C and F (4) A, C and E

82. The semiconservative nature of DNA replication was established by Meselson and Stahl in their classis experiment with bacteria. They grew bacteria in N^{15} - NH_4Cl containing medium, washed and then incubated in fresh medium with N^{14} -containing compounds and allowed to grow for three generations. CsCl density gradient centrifugation of isolated DNA

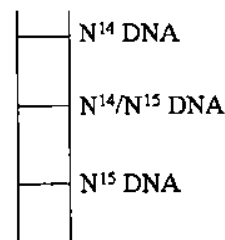

established the nature of semiconservative DNA replication. The pictorial representation below shows the position of differentially labeled DNA in CsCl density gradient.

Had the DNA replication been conservative, what would have been the pattern?

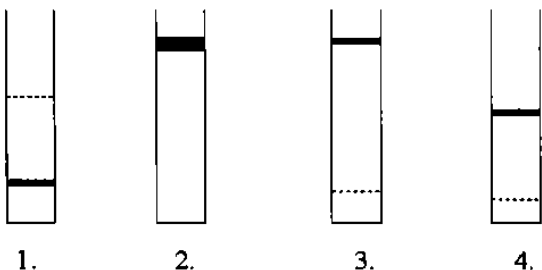

83. HeLa cell extract was used to study transcription of a gene X having six introns. RNA Pol II complex containing all associated proteins was isolated from actively transcribing system and subjected to proteome analysis. Results showed the presence of both splicing and capping enzymes in the complex. When transcription elongation was inhibited by flavopiridol, polymerase complex contained only capping enzymes. When phosphorylation of the CTD domain of Pol II was inhibited by a kinase inhibitor, the complex contained neither splicing nor capping enzymes. From these results, following conclusions were made:

- (A) Transcription of gene X is coupled to mRNA capping.
- (B) Transcription elongation is coupled to splicing
- (C) Phosphorylation of CTD is required for the recruitment of capping and splicing enzymes.
- (D) Both capping and splicing of mRNAs occurs simultaneously.

Identify the correct set of conclusions:

- (1) A, B and C
- (2) B, C and D
- (3) C, D and A
- (4) D, A and B

84. In bacteria, N-formyl methionine is the first amino acid to be incorporated into a polypeptide chain. Accordingly, one would think that all bacterial proteins have a formyl group at their amino terminus and the first amino acid is

methionine. However, this is not the case, because of the following possible reasons.

- (A) Deformylase removes the formyl group only during or after the synthesis of the polypeptides.
- (B) Aminopeptidase removes only the amino terminal, methionine.
- (C) Aminopeptidase removes the amino terminal methionine as well as one or two additional amino acids.
- (D) Deformylase removes the formyl group as well as amino terminal methionine and adds one or two amino acids to it.

Choose the combination of correct answer from the following:

- (1) B and C
- (2) A and B
- (3) A and C
- (4) A and D

85. Bacteriophage λ is a temperate phage. Immediately after infection, viral specific mRNAs for N and Cro proteins are expressed followed by early mRNAs. At the commitment phase, either lytic cycle starts with the expression of genes for head tail, and lytic proteins or lysogenisation cycle begins with the expression of repressor and integrase genes. During induction of lysogens both INT and XIS proteins are needed along with host factors. Out of the four processes below, some govern integration viral genome and its excision?

- (A) Repression of transcription
- (B) Retroregulation
- (C) Rearrangement of viral genome
- (D) Repression of translation

Identify the correct set of combination:

- (1) A and B
- (2) B and C
- (3) C and D
- (4) D and A

86. In E. coli, recA gene is involved in recombination as well as repair and dnaB gene is involved in unwinding of DNA double strands during replication. Which of the following statement is/are correct about Rec A and Dna B?

- (A) Mutation in E. coli recA gene is lethal.
- (B) E. coli with mutated dnaB gene does not survive.

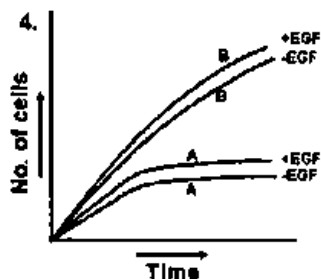

90. A particular type of cancer cell undergoes apoptosis by both extrinsic and intrinsic pathways when treated with a chemotherapeutic agent X. Caspase 8 and Caspase 9 are the initiator caspases associated with extrinsic and intrinsic pathways respectively. Now, if caspase 9 is silenced in the cancer cell by shRNA transfection, what will be the best-fit graph for apoptosis scenario in the cancer cell when treated with agent X?

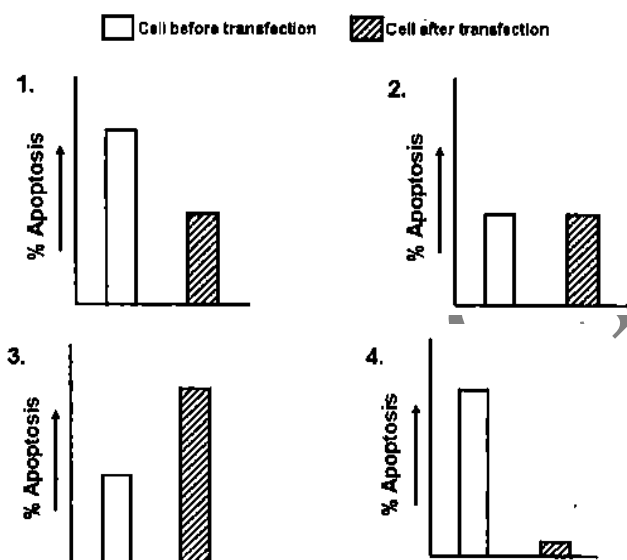

91. After successive surgery and chemotherapy. The tumor of a breast cancer patient subsided. However, after almost 5 years, the tumor relapsed in more aggressive manner and did not responded to the conventional chemotherapy delivered earlier. The following postulations were made.

- (A) Chemoresistant cells were persisting within the tumor even after therapy.
- (B) A population of quiescent cells existed, which under favourable conditions, transformed to new tumor cells.

- (C) High ABC (ATP-Binding Cassette) – transporter expressing cells persisted in the breast during chemotherapy.
- (D) Breast tumor cells which may have migrated to other tissues, returned to the breast immediately after chemotherapy was terminated.

Which of the above combination of statements is true?

- (1) A and D
- (2) A, B and C
- (3) only B
- (4) B and D

92. Following are the experimental observations made on treatment of B cells:

- (A) Anti-immunoglobulin (anti-Ig) antibody treatment results in B cell apoptosis.
- (B) Anti-Ig plus CD40 ligand treatment results in B cell proliferation.
- (C) Anti-Ig plus CD40 ligand plus IL-4 treatment results in B cell proliferation and switching to IgG1.
- (D) Anti-Ig plus IL4 treatment results in less B cell proliferation but switching to IgE.

From the above observation, which one of the following is the correct interpretation for the role of CD40 in B cell function?

- (1) Induce death of B cells.
- (2) Rescue B cells from death and Ig class switch to IgG1.
- (3) Inducing Ig class switch to IgE.
- (4) Induce Ig class switching to both IgG1 and IgE and inhibit B cell proliferation.

93. A potentially valuable therapeutic approach for killing tumor cells without affecting normal cells is the use of immunotoxins. Immunotoxins constitute monoclonal antibodies against tumor cells conjugated to lethal toxins. Which of the following molecular approaches do you think is NOT appropriate for generating tumor cell-specific immunotoxin that will not kill normal cells?

- (1) Cell surface receptor binding polypeptide chain of toxin molecule should be replaced by monoclonal antibodies against a particular tumor cell type.

- (2) Constant region Fc domain of tumor cell specific monoclonal antibody should be replaced by ligation of toxins.
- (3) Variable region F(ab)₂ domain of tumor cell-specific monoclonal antibody should be replaced by ligation of toxins.
- (4) Inhibitor polypeptide chain of toxin should be conjugated to F(ab)₂ domain of tumor cell specific monoclonal antibody.

94. Flowers represents a complex array of functionally specialized structures that differ substantially from the vegetative plant body in form and cell types. Following are statements made regarding floral meristems.

- (A) Floral meristems can usually be distinguished from vegetative meristems by their larger size.
- (B) The increase in the size of the meristem is largely a result of increased rate of cell division in central cells.
- (C) The increase in the size of the meristem is due to larger size of the cells, which in turn result from rapid cell expansion only.
- (D) A network of genes control floral morphogenesis in plants.

Which combination of the above statements is true?

- (1) A, B and D
- (2) A B and C
- (3) B, C and D
- (4) A, C and D

95. Three embryos, X (wild type), Y (mutant for bicoid) and Z (mutant for nanos) were injected with bicoid mRNA in their posterior pole at early cleavage stage. What would be the phenotypes of the resulting embryos?

- (1) Embryo X will develop head on both anterior and posterior side, while embryos Y and Z will develop head on posterior side only.
- (2) Embryos X and Z will develop head on both anterior and posterior side, while embryo Y will develop head on posterior end only.
- (3) Embryos X, Y and Z will develop head on both anterior as well as posterior side.
- (4) Embryo X will develop head on anterior side, embryo Y will develop no head, while

embryo Z will develop head on anterior as well as posterior side.

96. In *C. elegans* during embryogenesis, an anchor cell and 6 hypodermal vulval precursor cells (VPCs) get involved in forming the vulva. If 3 of the hypodermal VPCs are killed by a laser beam, a normal vulva is still formed. This could be due to the following possible reasons.

- (A) Six hypodermal VPCs form equivalence group of cells, out of which only 3 participate in vulva formation and 3 cells remain as reserve cells.
- (B) When 3 hypodermal VPCs are killed, the 3 neighboring hypodermal non-VPCs get freshly recruited.
- (C) Anchor cell functions as an inducer which can induce epithelial cells of the gonad to get recruited to compensate for the loss.
- (D) Anchor cell acts as an inducer which can spatially induce only 3 hypodermal cells to form the vulva.

Which combination of the above statements is correct?

- (1) A and B
- (2) B and C
- (3) C and D
- (4) A and D

97. In tadpoles, if the tail is amputated it can regenerate. However, if the tail is amputated and then exposed to retinoic acid, it develops limbs instead of regenerating the tail. This could be due to the following reasons:

- (A) Retinoic acid is a morphogen and induces genes responsible for limb formation.
- (B) Retinoic acid raises the positional values in that region for limb development to take place.
- (C) This is a random phenomenon and is not well understood
- (D) Retinoic acid possibly acts as a mutagen and the phenotype observed is a result of several mutations.

Which combination of the above statements is true?

- (1) A and B
- (2) C and D
- (3) B and D
- (4) B and C

98. In sea urchins, a group of cells at the vegetal pole become specified as the large micromere cells. These cells are determined to become skeletogenic mesenchyme cells that will leave the blastula epithelium to ingress into the blastocoel. This specification is controlled by the expression of Pmar1 which is a repressor of HesC. HesC represses the genes encoding transcription factors activating skeleton forming genes. The gene regulatory network is given below.

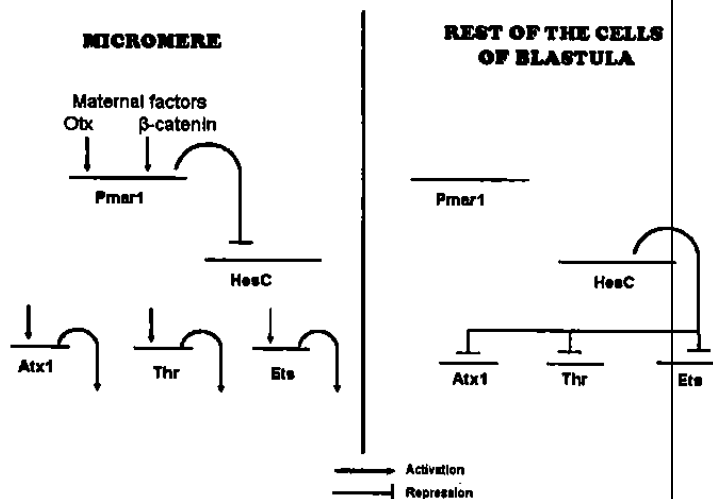

Below, column 1 lists the experiments carried with mRNA/antisense RNA of different genes injected into single-celled sea urchin embryo while column II lists the developmental outcomes.

Match the following:

Column – I (injection of)	Column – II (developmental outcomes)
A. mRNA of Pmar1	1. All cells will start ingressing into the blastocoel
B. mRNA of HesC	2. Skeleton mesenchyme will not be formed
C. Antisense of Pmar1	

D. Antisense of HesC	
----------------------	--

Which of the following combinations is correct?

- (1) A-2, B-1, C-1, D-2
- (2) A-1, B-1, C-2, D-2
- (3) A-1, B-2, C-2, D-1
- (4) A-2, B-2, C-2, D-2

99. Which of the following cellular communications shown below will override the process of normal development and lead to cancer?

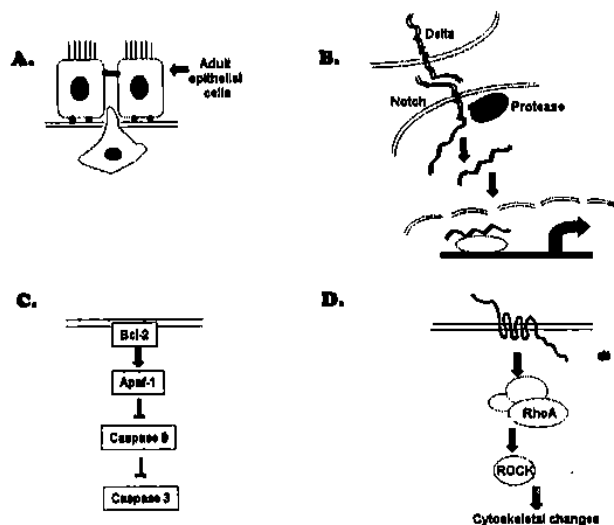

- (1) B and C
- (2) A and C
- (3) A and D
- (4) B and D

100. In plants, the energy of sunlight is first absorbed by the pigments present in their leaf cells followed by the fixation of carbon through photosynthesis. Consider the following statements.

- (A) Chlorophylls a and b are abundant in green plants.
- (B) Chlorophylls c and d are found in some protists and cyanobacteria.
- (C) Out of different types of bacteriochlorophyll, type a is the most widely distributed.
- (D) Out of different types of bacteriochlorophyll, type b is the most widely distributed.

Which one of the following combination of above statements is correct?

- (1) A, B and C (2) A, C and D
 (3) B, C and D (4) A, B and D

101. Nitrate reductase is an important enzyme for nitrate assimilation. Given below are some statements on nitrate reductase enzyme:

- (A) Nitrate reductase of higher plants is composed of two identical subunits.
 (B) One subunit of nitrate reductase contains three prosthetic groups.
 (C) One of the prosthetic groups attached to both subunits is heme.
 (D) One of the prosthetic groups complexed with pterin is magnesium.

Which one of the following combination of statements on nitrate reductase mentioned above is correct?

- (1) A B and C (2) A C and D
 (3) B C and D (4) A B and D

102. A farmer growing a particular variety of grape plants in vineyard, observes the following:

- (A) Fruit size normally remained small.
 (B) Natural seed abortion.
 (C) Development of fungal infection as the pedicels are small in size due to which moisture is retained in the bunches of grapes.

Experts suggested spraying gibberellic acid during the fruit development. This treatment would help in getting rid of

- (1) A B and C (2) only A and B
 (3) only A and C (4) only B and C

103. Light is perceived by various photoreceptors in plants. The photoreceptors predominantly work at specific wavelengths of light. Some of the following statements are related to the functions of plant photoreceptors.

- (A) Phytochrome A predominantly perceives the red and far-red light.
 (B) Phytochrome B predominantly perceives red light.
 (C) Cryptochromes regulate plant development.
 (D) Phototropins are involved in blue light perception and chloroplast movements.

Which one of the following combinations based on above statements is correct?

- (1) A B and C (2) B C and D
 (3) C D and A (4) A B and D

104. From the following statements:

- (A) Triose phosphate is utilized for the synthesis of both starch and sucrose.
 (B) Triose phosphate is translocated to cytosol from chloroplast.
 (C) Triose phosphate is confined to chloroplast and is utilized for synthesis of starch only.
 (D) Triose phosphate is translocated from cytosol to chloroplast.

Which one of the following combinations is correct regarding starch and sucrose synthesis during day time?

- (1) A and B (2) B and C
 (3) C and D (4) D and A

105.

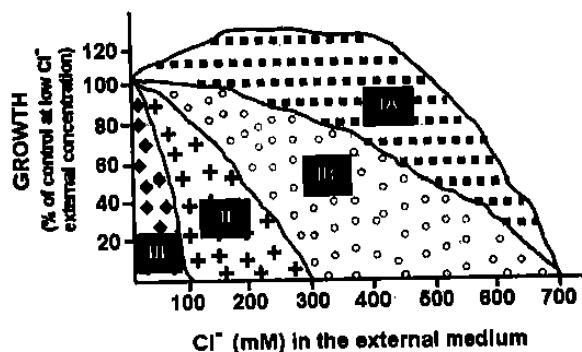

Shown above is a graph representing the growth of different plant species subjected to salinity relative to that of unsalinized control. Which of the following statements is NOT true?

- (1) Plants in group IA are extreme halophytes while very salt sensitive species will be part of group III.
 (2) Plants in group IA are very salt sensitive and extreme halophytes will be part of group III.
 (3) Halophytes, which can tolerate salt but their growth is retarded will be of part of group IB.

(4) Non-halophytes, which are salt tolerant but lacks salt glands will be a part of group II.

106. An experimentalist stimulates a nerve fibre in the middle of an axon and records the following observations. Which one of the observation is correct?

- (1) Nerve impulse is traveling in a direction towards cell body.
- (2) Nerve impulse is traveling in a direction towards telodendrons.
- (3) Nerve impulses are traveling in both the directions opposite to each other.
- (4) Nerve impulse is not moving in either direction.

107. Desert animals have longer loop of Henle compared to that of humans. It may be due to the following reasons:

- (A) Long loop of Henle is associated with greater amount of vasopressin secretion.
- (B) In long loop of Henle, the counter-current exchanger is more effective.
- (C) Long loop of Henle conserves more water.
- (D) Long loop of Henle stimulates production of angiotensin II.

Which of the above reason(s) is/are correct?

- (1) A and B
- (2) B and C
- (3) C and D
- (4) only D

108. A boy eats a large serving of cheese having high amount of sodium. He hardly drinks any fluid. In spite of this, the water and electrolyte balance was maintained. Which one of the following explanation is correct?

- (1) His aldosterone was decreased and alcohol dehydrogenase (ADH) was increased.
- (2) His aldosterone was increased and ADH was decreased.
- (3) There was no change in either of the hormones.
- (4) His sympathoadrenal system was stimulated.

109. The blood volume decreased when a mammal was bled rapidly. However, the cardiovascular changes resulting from hemorrhage could be

minimized by the following compensatory mechanisms:

- (A) Increased cerebral blood flow.
- (B) Reduction of baroreceptor activity and stimulation of chemoreceptors.
- (C) Reabsorption of tissue fluid in blood.
- (D) Increased release of enkephalins and beta-endorphins.

Which of the above is/are correct?

- (1) A and B
- (2) B and C
- (3) C and D
- (4) only D

110. The stomach of a person was partially removed during surgery of a gastric tumour. Despite taking a balanced diet, the person developed anemia. Following possible explanations were offered:

- (A) Lower gastric secretion inhibits folic acid absorption.
- (B) Protein digestion was disturbed in partial gastrectomy.
- (C) Lower HCl secretion from stomach reduced iron absorption.
- (D) Lower secretion of intrinsic protein factor from stomach reduced VitB₁₂ absorption

Which of the above explanations were correct?

- (1) A and B
- (2) B and C
- (3) C and D
- (4) A and D

111. The RFLP pattern observed for two pure parental lines (P1 and P2) and their F₁ progeny is represented below. Further, the P1 plant had red flowers while the P2 had white flowers. The F₁ progeny was backcrossed to P2. The result obtained, showing the number of progeny with red and white flowers and their RFLP patterns is also represented below.

	P1	P2	F ₁	Progeny of the cross between F ₁ and P2			
Phenotype	Red	White	Red	Red		White	
	—		—	—			—
RFLP pattern		—	—	—	—	—	—
		—	—	—	—	—	—

No. of progeny	45	5	45	5
----------------	----	---	----	---

Which one of the following conclusions made is correct?

- (1) The DNA marker and the gene for the flower colour are 10cM apart.
- (2) The marker and the gene for the flower colour are 5cM apart.
- (3) The marker and the phenotype are independently assorting.
- (4) The marker and the gene for the colour segregate from one another.

112. Wild type T4 bacteriophage can grow on B and K strains of E. coli forming small plaques, rII mutants of T4 bacteriophage cannot grow on E. coli strain K (non-permissive host), but form large plaques on E. coli strain B (permissive host). The following two experiments were carried out:

Experiment I: E. coli K cells were simultaneously infected with two rII mutants (a^- and b^-). Several plaques with wild type morphology were formed.

113. The following pedigree represents inheritance of a trait in an extended family:

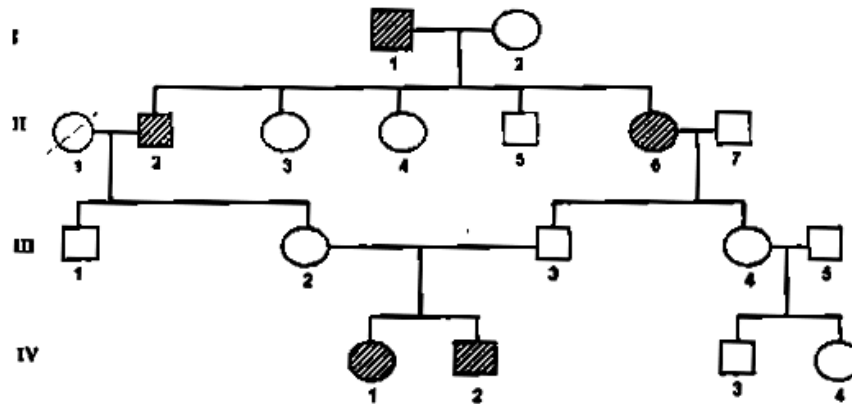

What is the probable mode of inheritance and which individuals conclusively demonstrate this mode of inheritance?

- (1) Autosomal recessive, III-2, 3 and IV-1, 2 conclusively demonstrate the mode of inheritance.
- (2) Autosomal recessive, I-1, 2 and II-2 conclusively demonstrate the mode of inheritance.
- (3) Autosomal dominant, III-2, 3 and IV-1, 2 conclusively demonstrate the mode of inheritance.
- (4) X-linked recessive, II-3, 4 and 5 conclusively demonstrate the mode of inheritance.

114. Following is the diagram of a paracentric inversion heterozygote

Experiment II: E. coli B cells were simultaneously infected with the same mutants as above. T4 phages were isolated from the resulting plaques and used to infect E. coli K cells, Few plaques with wild type morphology were formed.

Which one is the correct conclusion made regarding the rII mutants, a^- and b^- from the above experiments?

- (1) The mutations a^- and b^- belong to two different cistrons (experiment I) and there is no recombination between them (experiment II).
- (2) The mutations a^- and b^- belong to two different cistrons (experiment I) and they recombined (experiment II).
- (3) The mutations a^- and b^- belong to two different cistrons (experiment II) and they recombined (experiment I).
- (4) The mutants a^- and b^- belong to the same cistron (experiment I) and they did not recombine (experiment II).

ABCDEFG/ABFEDCG involved in recombination during meiosis I:

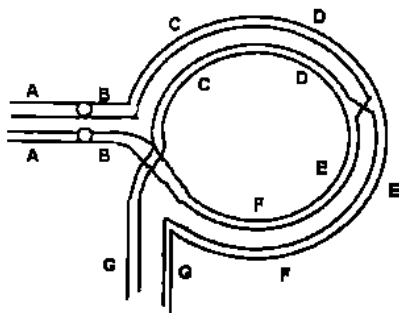

The consequence of this recombination will be the formation of

- (A) A dicentric and an acentric chromosome in meiosis I as the chiasmata gets terminated.
- (B) No dicentric or acentric chromosome but appearance of deletion and duplication in both the chromosomes.
- (C) All non-viable gametes.
- (D) Non-viable gametes from crossover products.

Which of the above statements are correct?

- (1) A and B
- (2) A and C
- (3) A and D
- (4) B and C

115. An E.coli strain has metB1 (90 min) and leuA5 (2 min) mutations. It also has strA7 (73 min) mutation and Tn5 transposon which confers streptomycin and kanamycin resistance, respectively, inserted in its chromosome. The mutant strain was crossed with an Hfr strain that is streptomycin sensitive and has a hisG2 mutation (44 min) that makes it require histidine. After incubation for 100 min, the cells were plated on minimal plate supplemented with leucine, histidine and streptomycin to select the metB marker. After purifying 100 of the Met⁺ transconjugants, one finds that 15 are His⁻, 2 are Leu⁺ and 12 are kanamycin sensitive. The unselected markers are

- (A) metB 1 and leuA 5 mutation
- (B) leuA 5 and Tn5 insertion mutation.

Which of the above statement is correct and what is the position of transposon insertion?

- (1) A and before 73 min
- (2) B and before 44 min

(3) B and before 73 min

(4) A and before 44 min

116. A chemist synthesized three new chemical compounds, M1, M2 and M3. The compounds were tested for their mutagenic potential and were found to be highly mutagenic. Tests were made to characterize the nature of mutations by allowing the reversion with other mutagens. The following results were obtained:

Mutations produced by	Reversed by			
	2-Aminopurine	Nitrous acid	Hydroxyl amine	Acridine orange
M1	No	No	No	No
M2	Yes	Yes	No	No
M3	No	No	No	Yes

Which one of the following conclusions drawn regarding the nature of mutations by the compounds is correct?

- (1) M1 – transversion, M2 – insertion, M3 – deletion.
- (2) M1 – transition, M2 – transversion, M3 – insertion.
- (3) M1 – insertion, M2 – transition, M3 – transversion.
- (4) M1 – transversion, M2 – transition, M3 – insertion.

117. Four Cnidarians with the following characteristics were observed:

- (A) Asexual polyps and sexual medusae; solitary or colonial; both freshwater and marine.
- (B) Polyp stage reduced or absent, medusae with velum; solitary; all marine.
- (C) Polyp stage reduced, bell shaped medusae; solitary; all marine.
- (D) All polyps, no medusae; solitary or colonial; all marine.

They can be identified to their respective classes:

- (1) A – Scyphozoa B – Anthozoa
- C – Cubozoa D - Hydrozoa

- (2) A – Hydrozoa B – Schyphozoa
C – Cubozoa D - Anthozoa
- (3) A – Anthozoa B – Cubozoa
C – Hydrozoa D - Scyphozoa
- (4) A – Cubozoa B – Scyphozoa
C – Anthozoa D - Hydrozoa

118. The following table shows the summary of characters between two taxa based on presence (1) and absence (0) data

		Taxon A	
		1	0
Taxon B	1	40	18
	0	22	20

Which of the following represents Jaccard's coefficient and Simole matching coefficient respectively?

- (1) 0.8, 0.5
(2) 0.6, 0.5
(3) 0.8, 0.6
(4) 0.5, 0.6

119. Identify the proteobacteria based on the key given below:

- | | |
|---|-------|
| (i) Cause disease in humans | (ii) |
| (i) Do not cause disease in humans | (iii) |
| (ii) An obligate intracellular parasite | (A) |
| (ii) Not an obligate intracellular parasite | (B) |
| (iii) Live in insects | (C) |
| (iii) Do not live in insects | (iv) |
| (iv) Chemoautotrophic | (D) |
| (iv) Not Chemoautotrophic | (v) |
| (v) Plant pathogen | (E) |
| (v) Not a plant pathogen | (vi) |
| (vi) Fix nitrogen | (vii) |
| (vi) Do not fix nitrogen | (F) |
| (vii) Associated with legumes | (G) |
| (vii) Not associated with legumes | (H) |

- (1) A – Rickettsia; B – Brucella; C – Wolbachia; D – Nitrobacter;
E – Agrobacterium; F – Acetobacter; G – Rhizobium; H – Azospirillum
- (2) A – Rickettsia; B – Wolbachia; C – Brucella; D – Nitrobacter;
E – Acetobacter; F – Agrobacterium; G – Rhizobium; H - Azospirillum
- (3) A – Rickettsia; B – Brucella; C – Wolbachia; D – Nitrobacter;
E – Agrobacterium; F – Acetobacter; G – Azospirillum; H - Rhizobium
- (4) A – Rickettsia; B – Brucella; C – Wolbachia; D – Nitrobacter;

E – Acetobacter; F – Agrobacterium; G – Azospirillum; H – Rhizobium

120. Which of the following phylogenetic trees appropriately uses principle of parsimony?

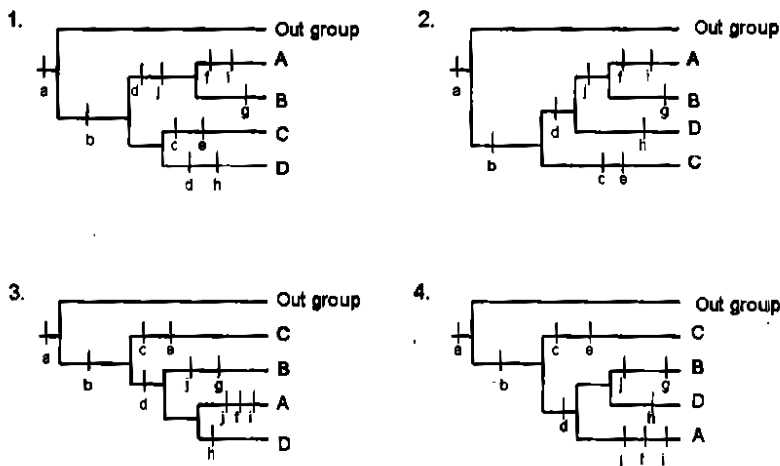

121. Identify the characters shown in the diagram depicting phylogenetic relationship among major groups of ferns and fern allies.

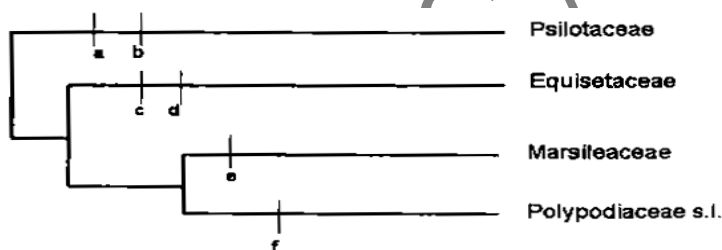

- (1) a) Roots absent, b) Sporangiphores, c) Vertical, interrupted annulus, d) Heterospory, e) Leaves scale like, f) Elasters.
- (2) a) Roots absent, b) Leaves scale like, c) Sporangiphores, d) Elasters e) Heterospory, f) Vertical, interrupted annulus
- (3) a) Leaves scale like, b) Sporangiphores, c) Elasters, d) Heterospory, e) Roots absent, f) Vertical, interrupted annulus.
- (4) Heterospory, b) Roots absent, c) Elaters, d) Sporangioshores, e) Leaves scale like, f) Vertical, interrupted annulus.

122. Associate the forest/vegetation type with the plants:

- (a) Grass land
- (b) Subalpine forest
- (c) Shola forest
- (d) Subtropical pine forest
- (e) Tropical thorn forest
- (f) Tropical dry deciduous forest
- (g) Tropical semievergreen forest

- (h) Tropical wet evergreen forest
- (1) a – Ilex, b – Dichanthium, c – Abies, d – Pinus, e – Acacia, f – Anogeissus, G – Cinnamomum, h – Dipterocarpus
- (2) a – Dichanthium, b – Abies, c – Ilex, d – Pinus, e – Acacia, f – Anogeissus, g – Cinnamomum, h – Dipterocarpus
- (3) a – Dichanthium, b – Abies, c – Ilex, d – Pinus, e – Dipterocarpus, f – Cinnamomum, g – Acacia, h – Anogeissus.
- (4) a – Anogeissus, b – Dichanthium, c – Ilex, d – Pinus, e – Acacia, f – Abies, g – Cinnamomum, h – Dipterocarpus

123. Possible explanations for the age related decline in primary productivity of trees are:

- (A) As trees grow larger with age, they have more tissues that respire and lose energy and proportionately less leaf area to photosynthesize.
- (B) Nutrient limitation by nitrogen due to reduced rate of woody litter decomposition as forest ages.
- (C) As trees become larger, water transport to the top canopy leaves becomes limited because of increased hydraulic resistance. This results in reduced stomatal conductance and reduction in photosynthetic rate.

Which of the above is/are correct?

- (1) A, B and C (2) only A
 (3) only A and C (4) only B and C

125. Based on the information given in the table below, which combination is correct?

Biographic zone	Plant	Animal
A ₁ Mediterranean	B ₁ - Rhododendron	C ₁ - Gibbon
A ₂ – Indo-Chinese	B ₂ – Dipterocarpus	C ₂ – Jungle Fowl
A ₃ – Indo – Malayan	B ₃ – Euphorbia	C ₃ – Takin
A ₄ – Peninsular India	B ₄ – Deodar	C ₄ – Ibex

- (1) A₁ – B₃ – C₃ (2) A₂ – B₁ – C₄
 (3) A₃ – B₂ – C₁ (4) A₄ – B₄ – C₂

124. Species characteristics that make them more prone to extinction are listed below:

- (A) High degree of specialization
 (B) High sexual dimorphism
 (C) High trophic status
 (D) Short life span

Which of the following is the correct combination?

- (1) A, B and C (2) A, C and D
 (3) A, B and D (4) B, C and D

126. In a census for a lake fish, 10 individuals were marked and released. In second sampling after a few days 15 individuals were caught, of which 5 individuals were found marked. The estimated population of the fish in the lake will be

- (1) 20 (2) 30
(3) 25 (4) 35

127. Identify the pollinators for the flowers with following pollination syndromes

- (A) Flowers dull colored, located away from foliage, floral parts turgid,
(B) Flowers bright red, crowded, turgid, nectar watery and sucrose rich.
(C) Flowers white with pleasant odor, corolla tube long, night blooming.

- (1) (A) Bird; (B) Bat; (C) Butterfly
(2) (A) Bat; (B) Bird; (C) Moth
(3) (A) Bat; (B) Bird; (C) Bee
(4) (A) Bird; (B) Bat; (C) Carrion fly

128. Which of the following combinations is good for setting up a nature reserve:



Linked reserves ii)



Large, compact shape



High edge-to-area ratio iv)



Surrounding area of same ecosystems

(1) (i), (ii), (iii)

(2) (ii), (iii), (iv)

(3) (i), (iii), (iv)

(4) (i), (ii), (iv)

129. If the number of new species evolving is directly proportional to the number of existing species and the probability of extinction of any species is inversely proportional to the number of existing species, the number of species present at a time during evolution will follow a curve given by:

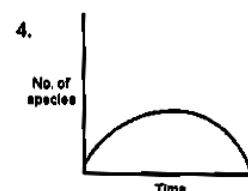
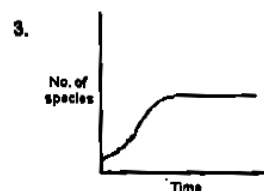
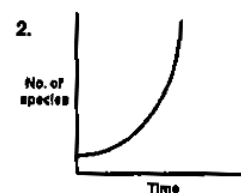
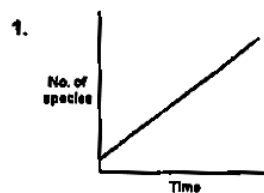

130. If the relationship between life time reproductive success and body size for males

and females of a species as shown in figure below:

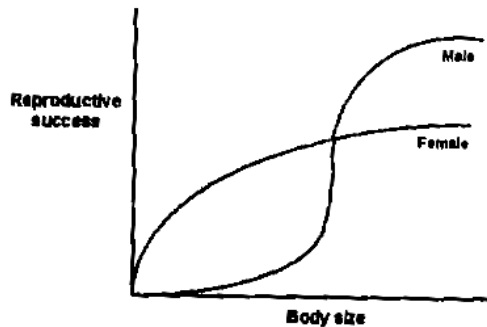

The species is most likely to evolve

- (1) sexual dimorphism
- (2) asexual reproduction
- (3) polyandry
- (4) obligate monogamy

131. Following tree represents phylogenetic relationships among species of a moth family. Circles represent species having eye spots on the wings. Other species do not have eye spots.

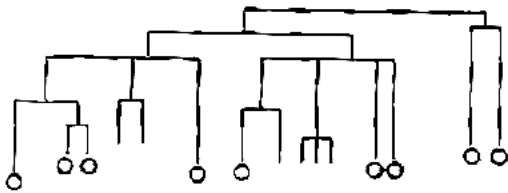

The following inferences were made by different researchers:

- (A) Eye spots were present in the ancestors and some species lost them.
- (B) Eye spots were not present in the ancestors.
- (C) Eye spots were lost more than once in evolution of the family.
- (D) Eye spots were gained only once while evolving from ancestor without them.

Which of the inferences are correct?

- (1) A and B
- (2) C and D
- (3) A and C
- (4) B and D

132. Wolbachia are obligate intracellular bacteria, many different strains of which are abundantly

present in insects. They induce mating incompatibility in host, i.e. males infected with one strain can only fertilize females infected with the same strain. No other pathological effects are observed in host. A possible evolutionary consequence of this phenomenon would be:

- (1) Extinction of many insect species.
- (2) Termination of sexual reproduction in many insect species.
- (3) Co-extinction of host and parasite.
- (4) Reproductive isolation leading to rapid speciation in insects.

133. Twenty small populations of a species, each polymorphic for a given locus (T, t) were bred in captivity. In 10 of them the population size was kept constant by random removal of individuals, while other 10 were allowed to increase their population size. After several generations it was observed that in 7 of the size restricted populations only T was present, in the remaining 3 only t was present. In the growing populations 8 retained their polymorphism and in 2 only t was observed. The experiment illustrates

- (1) Genetic drift which is more likely in large populations.
- (2) Genetic drift which is more likely in small populations.
- (3) Density dependent selection against T.
- (4) Density dependent selection against t.

134. Some important events in the history of life on Earth are given below.

- (A) First vertebrates (jawless fishes); first plants.
- (B) Forest of ferns and conifers; amphibians arise; insects radiate.
- (C) Conifers dominant; dinosaurs arise; insects radiate.
- (D) Flowering plants appear; climax of dinosaurs followed by extinction.
- (E) Radiation of flowering plants, most modern mammalian orders represented.
- (F) Ice Ages, Modern humans appear

Match the above with the geological time periods and choose the correct combination,

- (1) A – Silurian; B – Permian; C – Triassic; D – Jurassic; E – Cretaceous; F – Tertiary
- (2) A – Ordovician; B – Carboniferous; C – Triassic; D – Cretaceous; E – Tertiary; F – Quaternary.
- (3) A – Cambrian; B – Ordovician; C – Silurian; D – Devonian; E – Permian; F – Tertiary.
- (4) A – Devonian; B – Permian; C – Triassic; D – Cretaceous; E – Tertiary; F – Quaternary.

135. Microbes produce either primary or secondary metabolites during fermentation. A metabolite production curve is shown below:

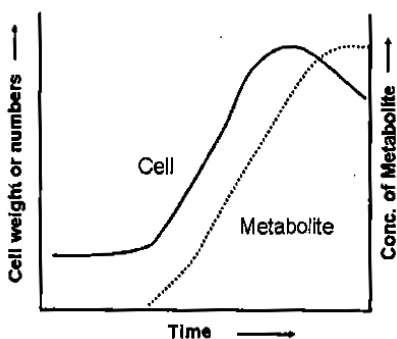

The following statements refer to the above figure:

- (A) A primary metabolite has a production curve that lags behind the line showing cell growth.
- (B) A primary metabolite is produced after the Trophophase is completed.
- (C) A secondary metabolite is produced mainly during Idiophase.
- (D) The curve shows the production of Penicillin from mold.

Which of the above statements are correct?

- (1) A and B
- (2) C and D
- (3) A and C
- (4) B and D

136. During transgenesis, the location of the genes and their number integrated into the genome of the transgenic animal are random. It is often necessary to determine the copy number of

genes and their tissue-specific transcription. The following are the possible methods used for the determination.

- (A) Polymerase Chain Reaction (PCR)
- (B) Reverse Transcriptase PCR
- (C) Southern blot hybridization
- (D) Western blot

Choose the correct setoff combinations.

- (1) A and B
- (2) B and C
- (3) B and D
- (4) A and D

137. *Agrobacterium tumefaciens*, also known as natural genetic engineers, causes crown-gall disease in plants. However, when the same bacteria are used to raise transgenic plants with improved agronomic traits, no such tumor (disease) is observed. This is due to:

- (A) Vir D₂ gene is mutated in Ti plasmid.
- (B) Disarmed Ti plasmid is generally used.
- (C) Heat-shock during transformation destroys virulence.
- (D) Oncogenes have been removed.

Which one of the following combination of above statements is correct?

- (1) A and C
- (2) A and D
- (3) B and C
- (4) B and D

138. Locus control region (LCR) lies far upstream from the gene cluster and is required for the appropriate expression of each gene in the cluster. LCR regulates expression of globin genes in the cluster through the following ways.

- (A) LCR interacts with promoters of individual genes by DNA looping through DNA-binding proteins.
- (B) The LCR-bound proteins attract chromatin-remodelling complexes including histone-modifying enzymes and components of the transcription machinery.
- (C) LCR acts as an enhancer for global regulation of gene cluster and does not regulate individual genes.
- (D) LCR participates in converting inactive chromatin to active chromatin around the gene cluster.

Choose the correct set of combinations.

- (1) A and B (2) A and C
 (3) B and C (4) B and D

139. A student wrote following statements regarding comparison of Restriction Fragment Length Polymorphism (RFLP), Random Amplified Polymorphic DNA (RAPD), Amplified Fragment Length Polymorphism (AFLP) and Simple Sequence Repeats (SSRs) techniques used for generating molecular markers in plants:

- (A) All these techniques can be used for fingerprinting.
 (B) Detection of allelic variation can be achieved only by RFLP and SSRs.
 (C) Use of radioisotopes is required in RFLP and RAPD only.
 (D) Polymerase chain reaction is required for all the techniques.

Which one of the following combination of above statements is correct?

- (1) A and B (2) B and C
 (3) C and D (4) D and A

140. In order to clone an eukaryotic gene in pBR322 plasmid vector, the desired DNA fragment was produced by PstI cleavage and incubated with PstI digested pBR322. (PstI cleavage site lies within the ampicillin resistant gene) and ligated. Mixture of ligated cells were used to transform E. coli and plasmid containing bacteria were selected by their growth in tetracycline containing medium. Which type of plasmid/s will be found?

- (1) Circular pBR322 plasmid containing the target gene and resistant to only tetracycline.
 (2) Circular pBB322 plasmid containing the target gene and resistant to tetracycline only and recircularised pBB322 plasmid resistant to both ampicillin and tetracycline.
 (3) Circular pBB322 plasmid containing the target gene and resistant to only tetracycline, recircularised pBB322 resistant to both ampicillin and tetracycline and concatemered pBB322

resistant to both ampicillin and tetracycline.

- (4) Circular pBR322 plasmid containing the target gene and resistant to both ampicillin and tetracycline.

141. During apoptosis, phosphatidyl serine (PS) usually present in the inner leaflet of the plasma membrane flips to the outer membrane. Annexin V is a protein that binds to PS. Using this as a tool, we identify the apoptotic cells from necrotic and normal cell populations by FACS using FITC-tagged Annexin V. Propidium iodide (PI) is used to stain the nucleus which generally identifies necrotic and late apoptotic cells. In which area of the plot you should get early apoptotic cells by FACS analysis?

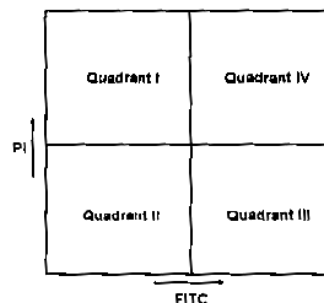

- (1) Quadrant I (2) Quadrant II
 (3) Quadrant III (4) Quadrant IV

142. The muscle tone was increased after electrolytic lesion of the **cardate** nucleus in a cat. The muscle tone decreased within seven days. The following explanations were given by the researcher.

- (A) The functional recovery was due to plastic changes of nervous system.
 (B) The brain tissue surrounding the lesioned area was non-functional due to circulatory insufficiency immediately after surgery which led to greater functional loss.
 (C) The circulatory status in surrounding tissue recovered with time resulting in partial functional recovery.
 (D) The degenerating nerve fibres were regenerated which underlie functional recovery.

Which one of the following is correct?

- (1) A and B (2) B and C
(3) C and D (4) A and D

- (3) 15 male 25 female
(4) 10 male 30 female

143. A fluorophore when transferred from solvent A to solvent B results in an increase in the number of vibrational states in the ground state without any change in the mean energies of either the ground or excited state. What would be the change seen in the fluorophore's emission spectrum?

- (1) An increase in emission intensity.
(2) An increase in emission bandwidth.
(3) An increase in emission wavelength.
(4) A decrease in emission wavelength.

144. You wish to localize a given product at subcellular levels following immunofluorescence staining. Routine microscopy could not resolve whether the gene product is localized inside the nucleus or on the nuclear membrane. Which of the following will resolve this unambiguously?

- (A) Sectioning of cell followed by phase contrast microscopy.
(B) A simulation of 3D picture following confocal microscopy.
(C) Optical sectioning and observing each section.
(D) Freeze fracturing followed by Scanning Electron Microscopy.

- (1) A and B (2) B and C
(3) C and D (4) A and C

145. The Triver-Willard hypothesis states that the physiological state of a female can bias the sex ratio of offspring. In an experiment in the bird species a group of females were fed a diet 30% lower in calories than the control females. After allowing both the groups to mate and breed freely, the offspring of control 1 group were 22 males and 18 females. The diet restricted females laid a total of 40 eggs. What should be the minimum deviation from the control to conclude that they have significantly female biased offspring sex ratio. (Chi sq [0.05] df = 1 is 3.84)

- (1) 18 male 22 female
(2) 20 male 20 female